**INSTALLATION INSTRUCTION, PARTS LIST
AND CONFIGURATION GUIDE**

FOR THE

BAR DISPENSER (BAR GUN)
Dispenser Model No. 950



NOTICE:

The information contained in this document is subject to change without notice.

SCHROEDER AMERICA MAKES NO WARRANTY OF ANY KIND WITH REGARD TO THIS MATERIAL, INCLUDING, BUT NOT LIMITED TO, THE IMPLIED WARRANTIES OF MERCHANTABILITY AND FITNESS FOR A PARTICULAR PURPOSE. SCHROEDER AMERICA shall not be liable for errors contained herein or for incidental consequential damages in connection with the finishings, performance, or use of this material.

This document contains proprietary information which is protected by copyright. All right reserved.

© Copyright 2015 by Schroeder America, all rights reserved.

THIS DOCUMENT CONTAINS IMPORTANT INFORMATION
This manual must be read and understood before the installation and operation of this dispenser.

Schroeder America
5620 Business Park • San Antonio, TX 78218
210.662.8200 • Fax: 210.667.2600 • www.schroederamerica.com
Toll-Free 877.404.2488

1. INSTALLATION

IMPORTANT

THIS EQUIPMENT TO BE INSTALLED WITH ADEQUATE BACKFLOW PROTECTION.

- A. Attach the base plate, smooth side out, in the desired location with #8 screws (supplied). The screws are slightly larger than the holes. This helps hold screws in position for mounting.
 - 1. To ensure base plate stability, please see Page 13 for best screw placement.
- B. Install inlet fittings, (supplied), to the flexible incoming beverage, soda, and water lines. (Be sure to use proper size hose clamps to secure tubing to inlet fittings).

NOTE:

If different screws are used for attaching the base plate, the head of the screw must fully seat inside countersink area. A screw head above the countersink surface will interfere with sliding the flow control modular (FCM) or mechanical modular (MM) assembly into the locking position.

- C. Follow the labeling on the assembly to ensure proper product connection.
- D. Lock inlet line fittings into FCM/MM module assembly using the red retainers before introducing product and water.
- E. Rotate yellow Shut-off stem 90 degrees to “Off” position to check for inlet connection leaks (Fig. 1.1).

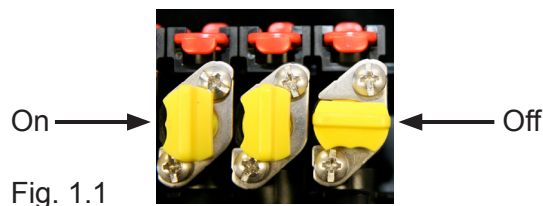

- F. Slide FCM/MM module on base plate until the red locking pin snaps in place (see Fig. 6.3).
 - 1. Adjacent to red locking pin (on the FCM/MM Module) are two knurled slotted plastic screws (Fig. 6.2). They are used to lock the module to the base plate. To attach the module to the base plate - push and turn screws clockwise, to release turn screws counterclockwise.

NOTE:

Screws are spring loaded to ensure screws will clear base plate.

NOTE:

The red retainer clips attached to the FCM or MM module must be flush with the bottom of the manifold. If the red retainer clips are not in place, the assembly will not slide into the base plate.

- G. Using the screws provided, install the holster and drain assembly in close proximity to the bar gun location. Holster mounting plate must be placed so that the release tab is accessible. Plumb the holster using 1/2” standard drain hose and within local plumbing codes. Refer to the cleaning and maintenance section for proper removal and cleaning of holster (Fig. 1.2).

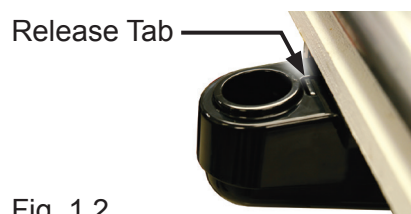

IMPORTANT

NEVER PLACE THE BAR DISPENSER HOLSTER DIRECTLY OVER THE ICE BIN.

NOTE:

Place your bar dispenser as close as possible to the product cooling source to minimize the dispensing of warm product and reduce foaming of the finished drinks.

2. RATIO/BRIX

The Schroeder Bar Dispenser has been thoroughly tested and sanitized prior to shipment. The installer will be required to ratio/brix the bar dispenser. A Schroeder Bar Dispenser syrup separator or refractometer may be used.

NOTE:

Sugar free products require a syrup separator. Installer must cool or chill the product before brixing the system. Ratio will be different between cold product and warm product.

IMPORTANT

BEFORE RATIO/BRIXING SYSTEM, PURGE PRODUCT AND WATER THROUGH BAR DISPENSER TO ENSURE PROPER PRODUCT TEMPERATURE.

- A. To adjust water flow rate, depress plain water button or carbonated water button on bar handle and capture water in a graduated cylinder (ratio cup) while timing the dispense. Divide the volume of water by the time. This will equal the flow rate.

NOTE:

The Schroeder America Bar Dispenser is designed to flow 1.25 oz/sec. or 6.25 oz/5 sec. This is the proper setting for 5:1 ratio.

- B. To adjust flow control assembly remove the red cap to expose the slotted red adjustment screw (Fig 2.1). To regulate flow, turn clockwise to increase flow and counterclockwise to decrease flow. If the flow control assembly contains a slotted green adjustment screw it is mechanical. To regulate flow, turn counterclockwise to increase flow and clockwise to decrease flow (opposite flow control).

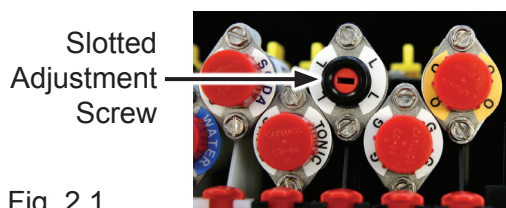

- C. To achieve the proper water flow rate, adjust the red/green screw within the flow control module. For the mechanical application adjust the green metering screw (Fig. 2.2).

NOTE:

Depending on the pressure of the incoming plain water, the maximum flow may not be achievable. There are two solutions to this problem.

- 1) Use slower flow rate. This will require ratio/brix adjustment.
- 2) Add a water booster to the system.

- D. To Ratio/Brix the final product, remove dispensing nozzle on bar gun assembly.
- E. Replace dispensing nozzle with the Schroeder America syrup separator nozzle. Rotate the separator in position to ensure seal against the diffuser.
- F. Adjust syrup flow to required ratio.

NOTE:

The Schroeder America Bar Dispenser is equipped with a secondary water ratio screw that is located on the bottom of the bar dispenser handle near the nozzle (Fig. 2.3). This may be used to slow the flow of water to maintain proper ratio for products with ratios 1:1 or 2:1 or any high-viscosity product. The screw comes from the factory in the open position and should be used only in the conditions noted. This screw only controls water flow to the products associated with the bottom right hand butterfly plate.

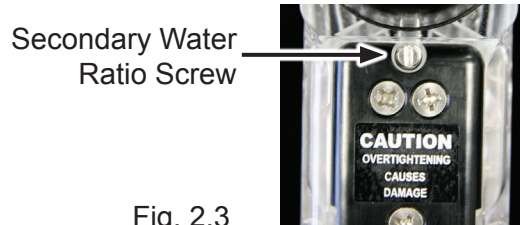

Fig. 2.3

3. BUTTERFLY PLATE REMOVAL/REASSEMBLY

Schroeder Bar Gun can be configured in numerous combinations. All combinations can be made without shutting down the product and soda/water support system.

The button plate can be removed while the bar dispenser is pressurized. Remove the two screws on the bar dispenser head. To change the button, place a slotted screw driver under the button and pry button off of button stem. Select a different button and snap onto the button stem.

To change configurations or combinations, the butterfly plates located below the button plate may need to be changed. Refer to the button plate diagrams in this manual on pages 12 through 15.

- A. To change butterfly plate, remove button plate.
- B. Remove both Phillips screws and special washers.
- C. Lift butterfly plates out of handle.
- D. Select desired butterfly configuration, (refer to back of manual for configurations).
- E. Align the pivot balls, located on the bottom of the butterfly plate, with the depressions in the bar gun handle.

NOTE:

The pivot balls on the butterfly plate must align with the dents in the bar gun handle for the bar gun dispenser to work properly.

- F. Secure butterfly plates in position using the Phillips screws and special washers, (be careful not to overtighten).
- G. Replace button plate and reattach with Phillips screws.

4. REMOVE AND REPLACE STEM O-RING

- A. Rotate yellow Shut-off stem 90 degrees, on module assembly, to turn off water/product.
- B. Place bar gun handle on flat surface, nozzle facing up.
- C. Remove (5) Phillips screws and the bottom plate.

NOTE:

Carefully remove bottom plate, by lifting straight up. Small springs are located below the plate.

- D. Remove the small loose springs.
- E. Using a small pin or paper clip, push valve stem down and out of the handle.
- F. To remove the water or soda valve stem it will be necessary to remove the butterfly plates. The water and soda valve stems are located under the plates.
- G. Use the spear end of the o-ring tool (P.N. 316-0003) to remove the o-ring (P.N. 208-1003) to be replaced.
- H. Place new o-ring on the plain end of the tool, lubricate with a small amount of lubricant.
- I. Install o-ring into hole in the handle making sure it is firmly seated at the end or bottom of the channel.

NOTE:

It is important that a food grade lubricant is used.

- J. Replace valve stem, install springs in the valve handle.

IMPORTANT

ALL VALVE SPRINGS MUST BE SEATED IN THE RECESS OF THE BOTTOM PLATE TO PROPERLY ALIGN THE BOTTOM PLATE.

- K. Slowly press valve plate in handle so it is completely seated.
- L. While holding the valve plate, replace the (5) retaining screws.

NOTE:

Do not over tighten.

- M. If applicable, replace butterfly plates.
- N. Replace button plate.

5. REPLACING/ADDING PRODUCT TUBING

tubing - the bar gun dispenser has been manufactured with a special liner to prevent contamination by pungent syrup products. The tube should not have to be changed when a syrup product is changed.

- A. Rotate yellow Shut-off stem 90 degrees to turn off water/product.
- B. Pull out red locking pin on bar gun dispenser assembly.
- C. Slide assembly out of mounting plate.
- D. Snap the red retainer clips to the open position (away from flow controls).

NOTE:

All red retainers must be in the open position to remove the bar gun dispenser.

- E. Locate the two slotted red screws on the outside of the bar gun dispenser. Rotate the red screws clockwise. This will separate the bar gun dispenser from the FCM/MM module.

NOTE:

The Shut-off tool (P.N. 316-0005), or a screwdriver, can be used to aid in removing the dispenser assembly but is not necessary. The red screws can be turned by hand with no tools.

- F. Remove (5) Phillips screws and remove product line cover. This will expose the beverage tubing.

NOTE:

All tubes are numbered. Each line is a different length to prevent damage to the tube.

- G. Remove (4) Phillips screws recessed in the bar gun handle heel assembly. Slide the heel assembly away from bar handle, this will expose the stainless fitting retainer plate holding the tubing.
- H. Remove the hex studs. Slide back stainless fitting retainer plate.
 - I. Remove bar gun handle from plug-in fittings and cut-off bar handle fitting from the tube being replaced. Remove the fitting from the manifold cover that corresponds with the cut line (a diagram is provided on the manifold cover).
- J. Slide the tube assembly from the sheathing.
- K. Replace tubing with the same product number. (S1, S2, Etc.)
- L. Slide the new tube, without the bar handle fitting attached, through the sheath from the manifold housing towards the bar handle end and through the stainless fitting retainer.
- M. Assemble the bar handle fitting with the plastic ferrule to the new tube.
- N. Following the diagram provided, reconnect all tube assemblies to the bar handle.
- O. Slide stainless fitting retainer against bar gun handle and replace hex studs.

IMPORTANT

WHEN REINSERTING STAINLESS FITTING RETAINER PLATE, IT IS IMPORTANT TO NOTE THAT THE TOP (“UP”) POSITION IS IDENTIFIED ON THE PLATE. IMPROPER ASSEMBLY WILL RESULT IN IMPROPER TUBE ALIGNMENT.

- P. Slide sheathing cap over hex studs and replace (4) Phillips screws.
- Q. Snap new product tubing into its position in the product line housing.
- R. Reassemble product line cover to the housing.

NOTE:

Sheathing flange must sit in slot provided for cover to seat properly.
Exercise caution not to kink line when replacing cover.

- S. Reattach bar gun handle assembly to the FCM/MM module.

6. CLEANING AND MAINTENANCE

The Schroeder America Bar Dispenser is shipped from the factory cleaned and sanitized in accordance with NSF guidelines. The bar dispenser must also be cleaned and sanitized after installation is complete. It is recommended that the operator provide continuous maintenance as required by the manual and/or state and local guidelines to ensure proper operation.

IMPORTANT

DO NOT SUBMERGE THE BAR DISPENSER IN HOT WATER. THIS WILL CAUSE PERMANENT DAMAGE TO THE DISPENSER AND ITS COMPONENTS.

A. External Cleaning

Cleaners (ivory liquid, calgon, etc.) should be mixed with clean potable water at a temperature of 90 to 110 degrees F. The acceptable mixture ratio is one ounce of cleanser to two gallons of water. Any NSF approved equivalent cleaner may be used. Rinsing must be thorough using clean potable water.

IMPORTANT

ONLY USE INTERNAL CLEANING SOLUTIONS THAT ARE APPROVED FOR BEVERAGE DISPENSER APPLICATIONS, SUCH AS BevClean™. (NO CAUSTIC CHEMICALS SUCH AS INDUSTRIAL KITCHEN CLEANING CHEMICALS SHOULD EVER BE USED)

B. Sanitizing

Sanitizing solutions must provide 50 to 100 parts per million (PPM) available chlorine. Any sanitizing solution may be used as long as it is prepared in accordance with the manufacturer's recommendations.

C. Daily Cleaning

1. Dispenser Handle

Remove nozzle from bar dispenser handle. Fill container about 6" with warm (never hot) water. Allow the dispenser handle and nozzle to soak in the water for 10 to 15 minutes. This will remove any syrup or soda residue from the nozzle and buttons.

NOTE:

It is recommended that the nozzle be removed and cleaned daily.

2. The stainless steel sheathing, which connects the bar gun handle to the FCM/MM module, can be cleaned by wiping with a cloth soaked with warm cleansing detergent. Inspect the hose to ensure all residue is removed.

D. Deep Cleaning

NOTE:

For deep cleaning, the stainless steel sheathing should be sanitized bi-weekly.

1. Rotate yellow Shut-off stem 90 degrees to turn off water/product (Fig. 6.1).
2. Turn the two (2) knurled slotted plastic screws adjacent to the red locking pin counterclockwise to release the FCM/MM from the base plate (Fig. 6.2).

NOTE:

Screws are spring loaded to ensure screws will clear base plate.

3. Pull out red locking pin on bar gun dispenser assembly (Fig. 6.3).
4. Slide FCM/MM module out of mounting plate (Fig. 6.4).
5. Snap the red retainer clips to the open position (Fig. 6.5).

NOTE:

All red retainers must be in the open position to remove the bar gun dispenser.

6. Locate the two slotted red screw separators on the outside of the bar gun manifold and turn the screws clockwise. This will separate the bar gun dispenser from the FCM/MM module (Fig. 6.6).

NOTE:

Alternate turning each separator screw to evenly remove the bar gun manifold from the module. The Shut-off tool (P.N. 316-0005), or a screw driver, can be used to aid in removing the dispenser assembly but is not necessary. The red screws can be turned by hand with no tools.

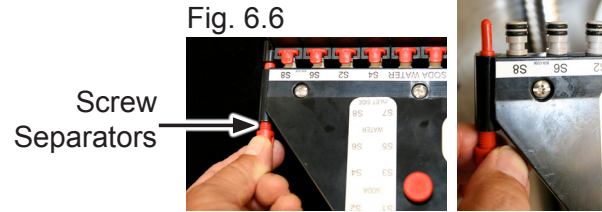
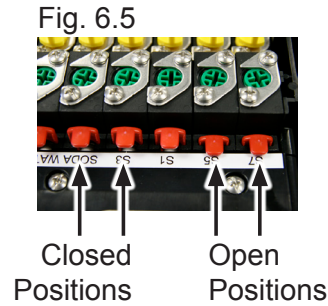
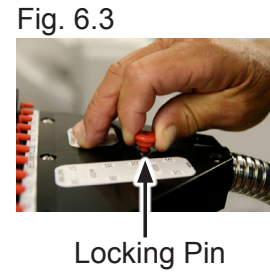
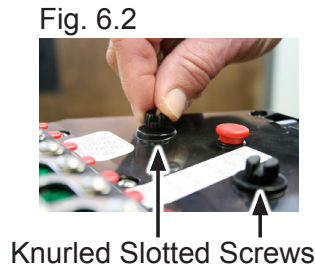
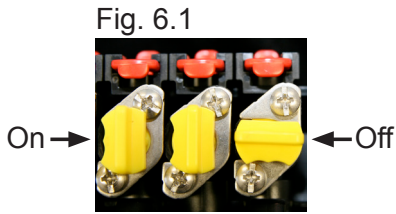

7. Fill a bar sink or a 5 gal. bucket with sanitizing solution that is mixed to mfg. recommendations (50 to 100 PPM). Allow the bar gun assembly to soak in the solution for 10 to 15 minutes. Using a cloth and brush, wash and clean the hose. Inspect the hose to ensure all residue is removed.
 8. Rinse with warm water and allow to dry.
- E. Holster Cleaning
1. Daily Cleaning
For daily cleaning, press carbonated water button or water button on bar handle while sitting in the holster to flush product residue down drain. You may also pour warm water down the receptacle to clean holster.
 2. Bi-weekly Cleaning
 - a. To remove holster assembly, push tab located behind the nozzle receptacle. Slide holster assembly forward (toward you) (Fig. 6.7).
 - b. Separate the bar gun receptacle from the drip tray (Fig. 6.8).
 - c. Refer to sanitizing section in 6-B.



NOTE:
Check the back of the drip tray drain connector to ensure there is no damage to the o-rings (P.N. 208-0112-429) (Fig. 6.9).

7. REATTACHING THE BAR GUN ASSEMBLY

- A. Adjust the red screw separators on the outside of the bar gun assembly so the small smooth shank is exposed.
- B. Slide the bar gun manifold into the FCM/MM module.
- C. Snap red retainers into the locked position.
- D. Slide FCM/MM module and bar dispenser into locked position on mounting plate.
- E. Push and turn the two (2) knurled slotted plastic screws adjacent to the red locking pin clockwise to attach the FDM/MM module to the base plate.
- F. Rotate yellow Shut-off stem 90 degrees to the open position and check for leaks.
- G. Depress all buttons on bar dispenser head to remove any trapped air or sanitizing solution.
- H. Bar Dispenser is ready for operation.

8. TROUBLE SHOOTING

- A. Push water - no water dispensed
 - Check water supply
 - Check Shut-off (is it open)
 - Check ratio/brix adjustment
 - Check for proper butterfly plate
- B. Push syrup - no syrup dispensed
 - Check CO₂ pressure
 - Check for product
 - Check Shut-off
 - Check ratio/brix adjustment
 - Line plugged
- C. Push soda - no soda dispensed
 - Check carbonator
 - Check water supply
 - Check CO₂ pressure
 - Check Shut-off
 - Check ratio/brix adjustment
 - Check for proper butterfly plate
- D. Push product - dispensing incorrect product
 - Check for proper plumbing
 - Check for proper butterfly plate
- E. Weak product taste
 - Check syrup CO₂ supply
 - Check ratio/brix adjustment
 - Check for plugged line
 - Check Shut-off - completely open
 - Check syrup supply
- F. Strong product taste
 - Check ratio/brix adjustment
 - Check carbonator pressure
 - Check syrup CO₂
- G. Continuous dispense
 - Check butterfly plates - damaged or too tight
 - Check for debris in syrup or water passages
- H. Product leaking from bottom plate
 - Defective stem o-ring
 - Bottom plate screws are loose
 - Warped or damaged button plate

JUICE AND ENERGY BUTTON PLATE CONFIGURATION

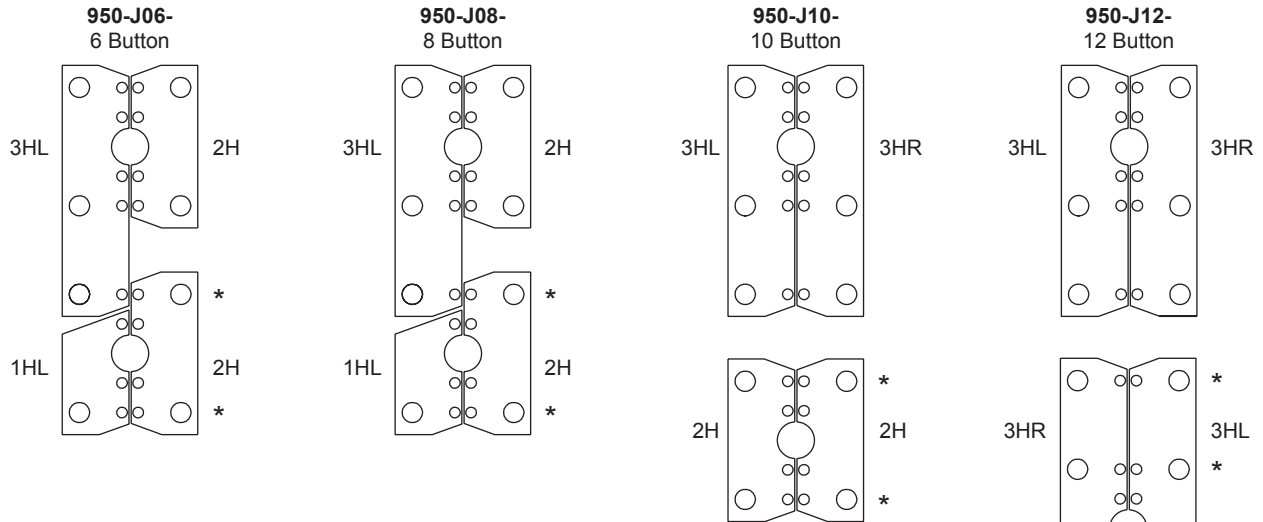

#H	Butterfly Plate Assy Part Number
1HL	634-0001
1HR	634-0002
2H	634-0003
3HL	634-0004
3HR	634-0005
4HL	634-0006
4HR	634-0007
4H#3	634-0008
4H#4	634-0009



● = Carbonated Positions
 ○ = Non-Carbonated Positions
 #H = See Chart on Page 10 for Part Number

* = Secondary Water Metering Screw Affects These Positions
 ® = Requires Soda/Water Button Foot (P.N. 265-0039/265-0040)
 Extensions Into Bottom Of Button Where Symbol Appears.

8 AND 10 BUTTON PLATE CONFIGURATIONS

950-10800-
 8 Button Carbonated
 0 Button Non-Carbonated
 0 Pre-Mix

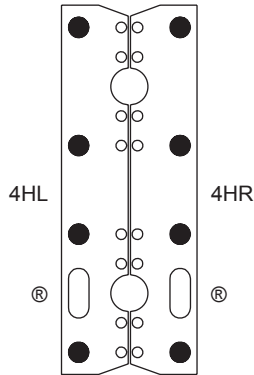

950-10710-
 7 Button Carbonated
 1 Button Non-Carbonated
 0 Pre-Mix

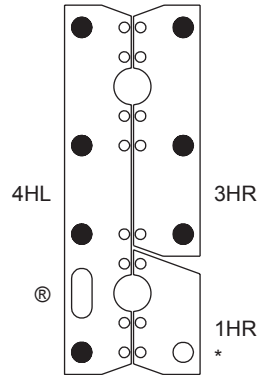

950-10620- & 950-08600-
 6 Button Carbonated
 2 Button Non-Carbonated
 0 Pre-Mix

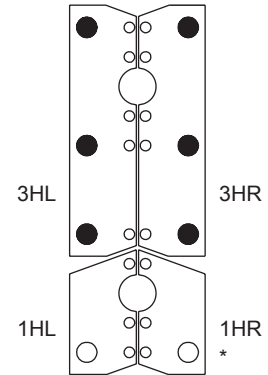

950-10530- & 950-08510-
 5 Button Carbonated
 3 Button Non-Carbonated
 0 Pre-Mix

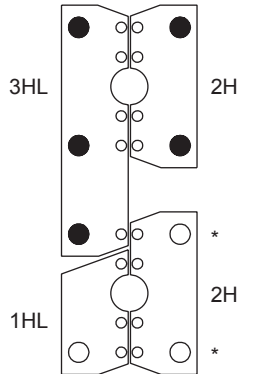

950-10440-
 4 Button Carbonated
 4 Button Non-Carbonated
 0 Pre-Mix

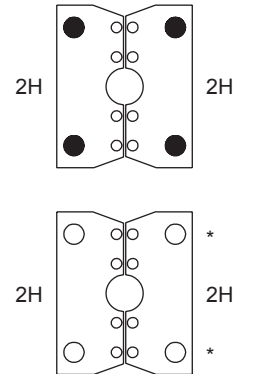

950-10350-
 3 Button Carbonated
 5 Button Non-Carbonated
 0 Pre-Mix

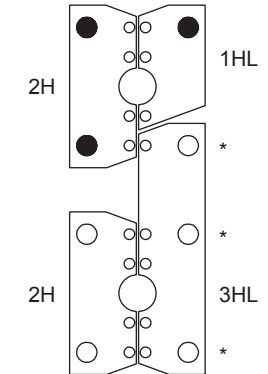

950-10260-
 2 Button Carbonated
 6 Button Non-Carbonated
 0 Pre-Mix

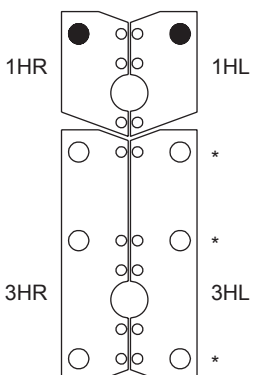

950-10170-
 1 Button Carbonated
 7 Button Non-Carbonated
 0 Pre-Mix

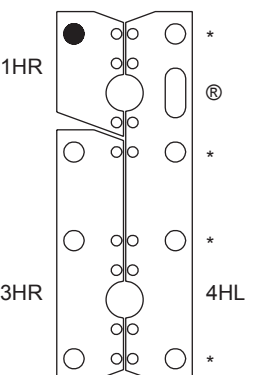

950-10080-
 0 Button Carbonated
 8 Button Non-Carbonated
 0 Pre-Mix

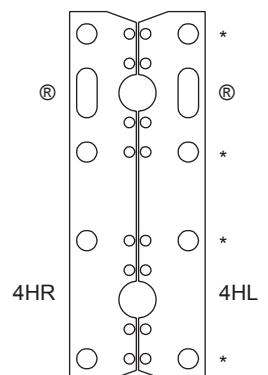

● = Carbonated Positions
 ○ = Non-Carbonated Positions
 #H = See Chart on Page 10 for Part Number

* = Secondary Water Metering Screw Affects These Positions
 ® = Requires Soda/Water Button Foot (P.N. 265-0039/265-0040)
 Extensions Into Bottom Of Button Where Symbol Appears.

12 AND 14 BUTTON PLATE CONFIGURATIONS

950-12820-
 8 Button Carbonated
 2 Button Non-Carbonated
 0 Pre-Mix

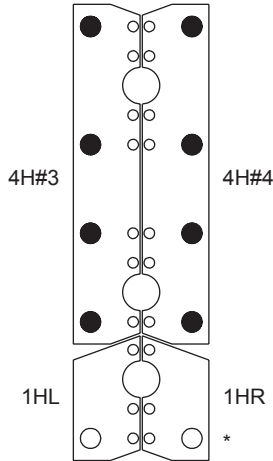

950-12730-
 7 Button Carbonated
 3 Button Non-Carbonated
 0 Pre-Mix

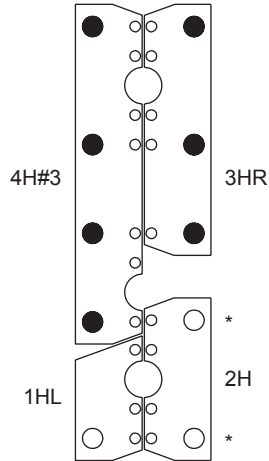

950-12640-
 6 Button Carbonated
 4 Button Non-Carbonated
 0 Pre-Mix

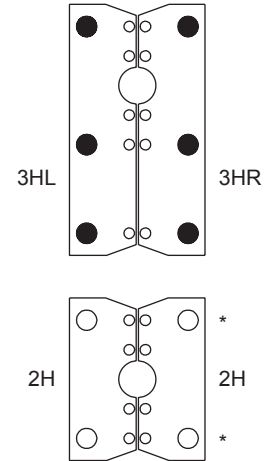

950-12550-
 5 Button Carbonated
 5 Button Non-Carbonated
 0 Pre-Mix

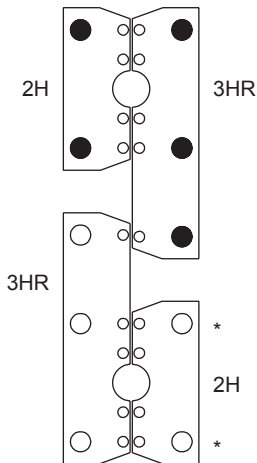

950-12460-
 4 Button Carbonated
 6 Button Non-Carbonated
 0 Pre-Mix

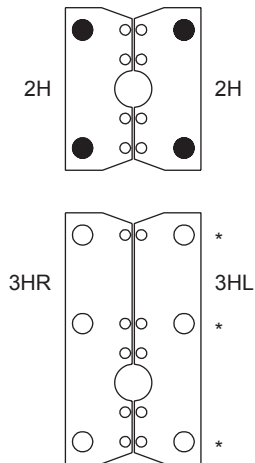

950-12370-
 3 Button Carbonated
 7 Button Non-Carbonated
 0 Pre-Mix

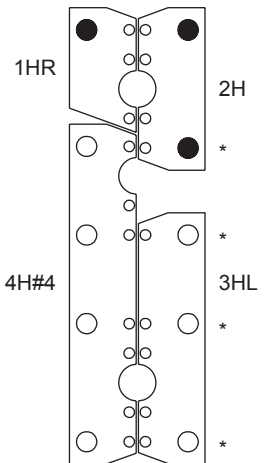

● = Carbonated Positions
 ○ = Non-Carbonated Positions
 #H = See Chart on Page 10 for Part Number

* = Secondary Water Metering Screw Affects These Positions
 ® = Requires Soda/Water Button Foot (P.N. 265-0039/265-0040)
 Extensions Into Bottom Of Button Where Symbol Appears.

12 AND 14 BUTTON PLATE CONFIGURATIONS

950-12280-
 2 Button Carbonated
 8 Button Non-Carbonated
 0 Pre-Mix

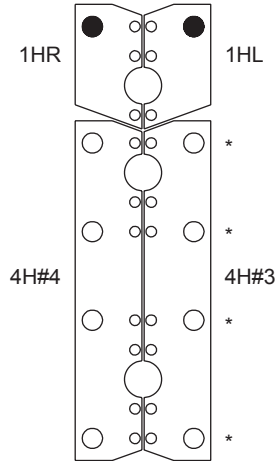

950-14840-
 8 Button Carbonated
 4 Button Non-Carbonated
 0 Pre-Mix

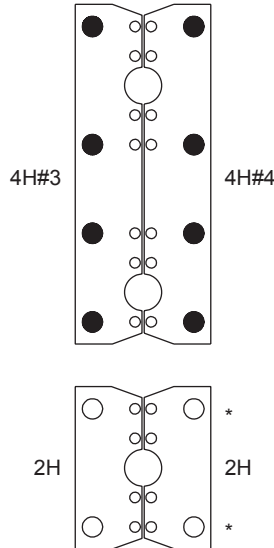

950-14750-
 7 Button Carbonated
 5 Button Non-Carbonated
 0 Pre-Mix

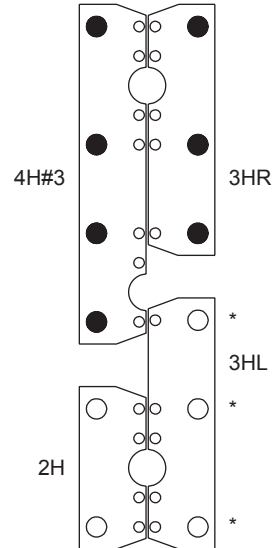

950-14660-
 6 Button Carbonated
 6 Button Non-Carbonated
 0 Pre-Mix

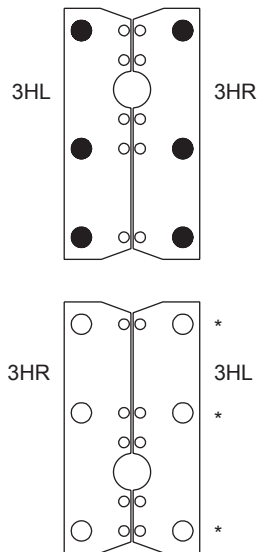

950-14570-
 5 Button Carbonated
 7 Button Non-Carbonated
 0 Pre-Mix

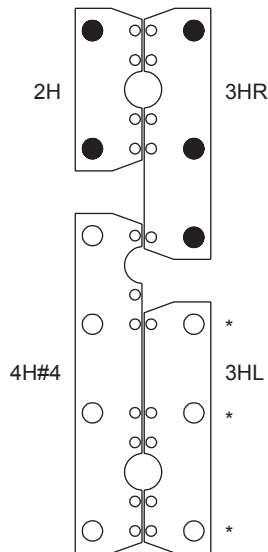

950-14480-
 4 Button Carbonated
 8 Button Non-Carbonated
 0 Pre-Mix

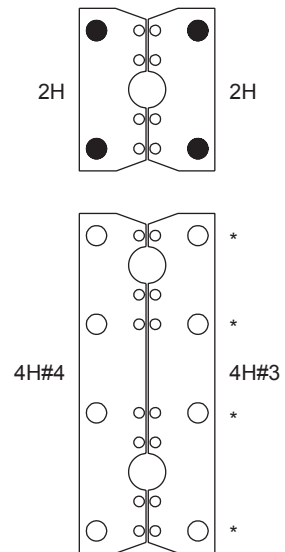

● = Carbonated Positions
 ○ = Non-Carbonated Positions
 #H = See Chart on Page 10 for Part Number

* = Secondary Water Metering Screw Affects These Positions
 ® = Requires Soda/Water Button Foot (P.N. 265-0039/265-0040)
 Extensions Into Bottom Of Button Where Symbol Appears.

ACCESSORIES

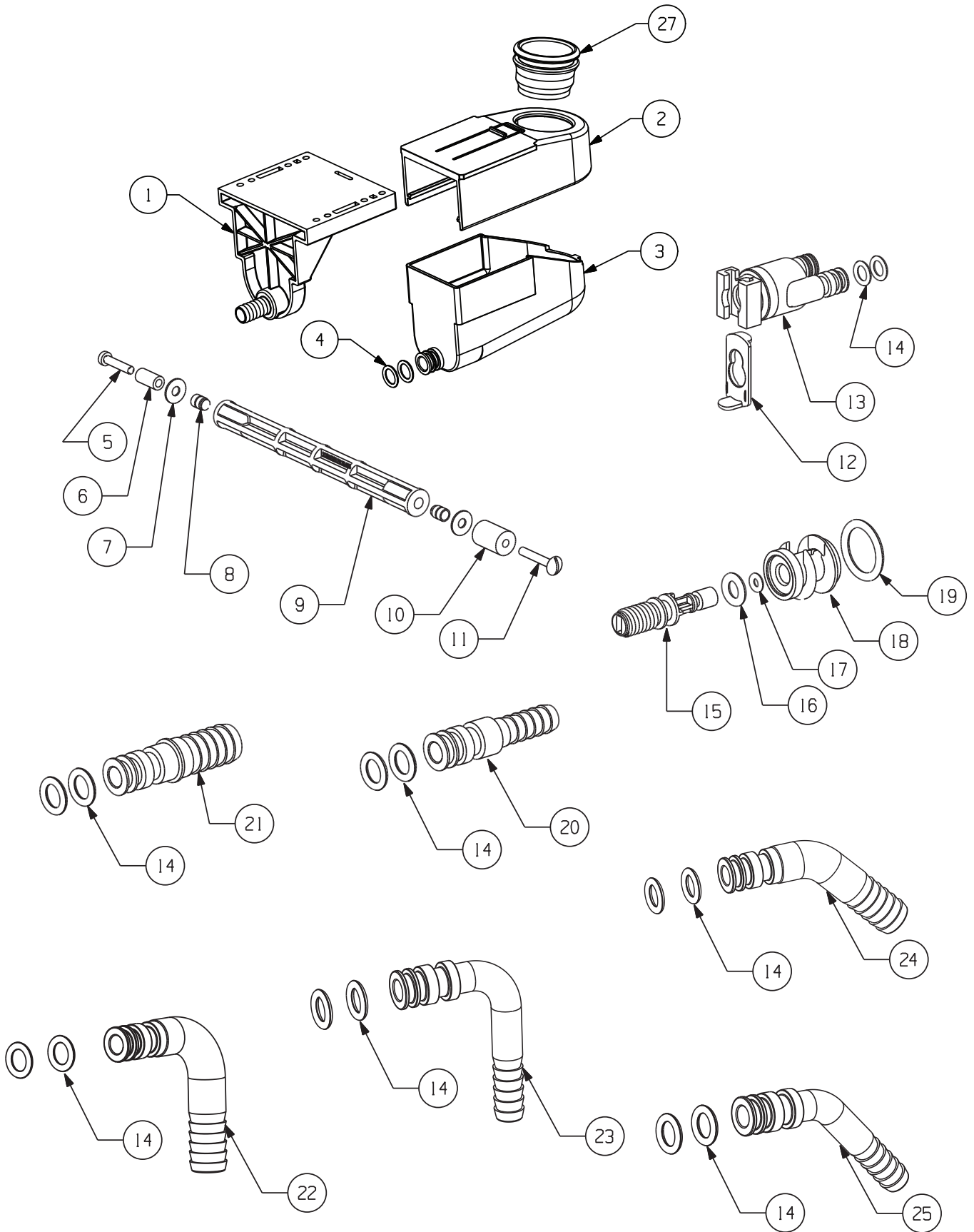

ACCESSORIES

ACCESSORIES PARTS LIST		
ITEM	SCHROEDER PN	DESCRIPTION
1	265-0153	BRACKET, MOUNTING, BARGUN, BLACK
2	265-0151	HOLSTER, BARGUN, BLACK
3	265-0152	DRIP TRAY, BARGUN, BLACK
4	208-0112-429	O-RING, 2-112
5	220-0016	SCREW, 8-32 X .750, PH, FHD, SS
6	249-0006	GROMMET, PISTON, .281
7	240-0006	WASHER, NYLON
8	253-0003	INSERT, ULTR IV-8
9	265-0171	HANDLE, TOOL
10	249-0005	GROMMET, SLEEVE, .500
11	220-0017	SCREW, 8-32 X 1.000, SL, TH, SS
12	265-0063	RETAINER, CLIP, FITTING
13	631-0039	SPLITTER SUB-ASSY, WATER, BARGUN
14	208-0010	O-RING, 2-010
15	265-0070	PLUG, ADJUST, MC, GREEN
16	208-0108	O-RING, 2-108
17	208-0006	O-RING, 2-006
18	265-0099	CONTROL, ORIFICE
19	208-0114	O-RING, 2-114
20	279-0016	FITTING, .375 O-RING X .250 BARB
21	279-0017	FITTING, .375 O-RING X .375 BARB
22	279-0025	FITTING, 90 DEG, .375 O-RING X .375 BARB
23	279-0027	FITTING, 90 DEG, .375 O-RING X .250 BARB
24	279-0026	FITTING, 45 DEG, .375 O-RING X .375 BARB
25	279-0028	FITTING, 45 DEG, .375 O-RING X .250 BARB
26	NOT USED	
27	315-0016	INSERT, HOLSTER, SHORT
ACCESSORIES ASSEMBLED PARTS LIST		
	030-0017	DRAIN TUBE 1/2 ID X 3/4 OD
	675-0017	KIT, HOLSTER ASSY, W/SCREWS/BG, BLK
	316-0005	SHUT-OFF TOOL
	316-0006	FLOW CONTROL TOOL
	316-0003	O-RING TOOL
	316-0004	SEPARATOR, BARGUN
	279-0014	EXTENSION, ACTUATOR, WATER/SODA
	265-0083	ACTUATOR, SINGLE, PREMIX
	625-0004	FITTING ASSY, .375 O-RING X .250 BARB W/O-RINGS
	625-0005	FITTING ASSY, .375 O-RING X .375 BARB W/O-RINGS
	625-0011	FTG ASSY, 90 DEG, .375 O-RING X .375 BARB W/O-RINGS
	625-0012	FTG ASSY, 45 DEG, .375 O-RING X .375 BARB W/O-RINGS
	625-0013	FTG ASSY, 90 DEG, .375 O-RING X .250 BARB W/O-RINGS
	625-0014	FTG ASSY, 45 DEG, .375 O-RING X .250 BARB W/O-RINGS
	675-0005	KIT, MECHANICAL ORIFICE CONTROL
	631-0049	SPLITTER ASSY, WATER, BARGUN W/O-RINGS

HANDLE ASSEMBLY

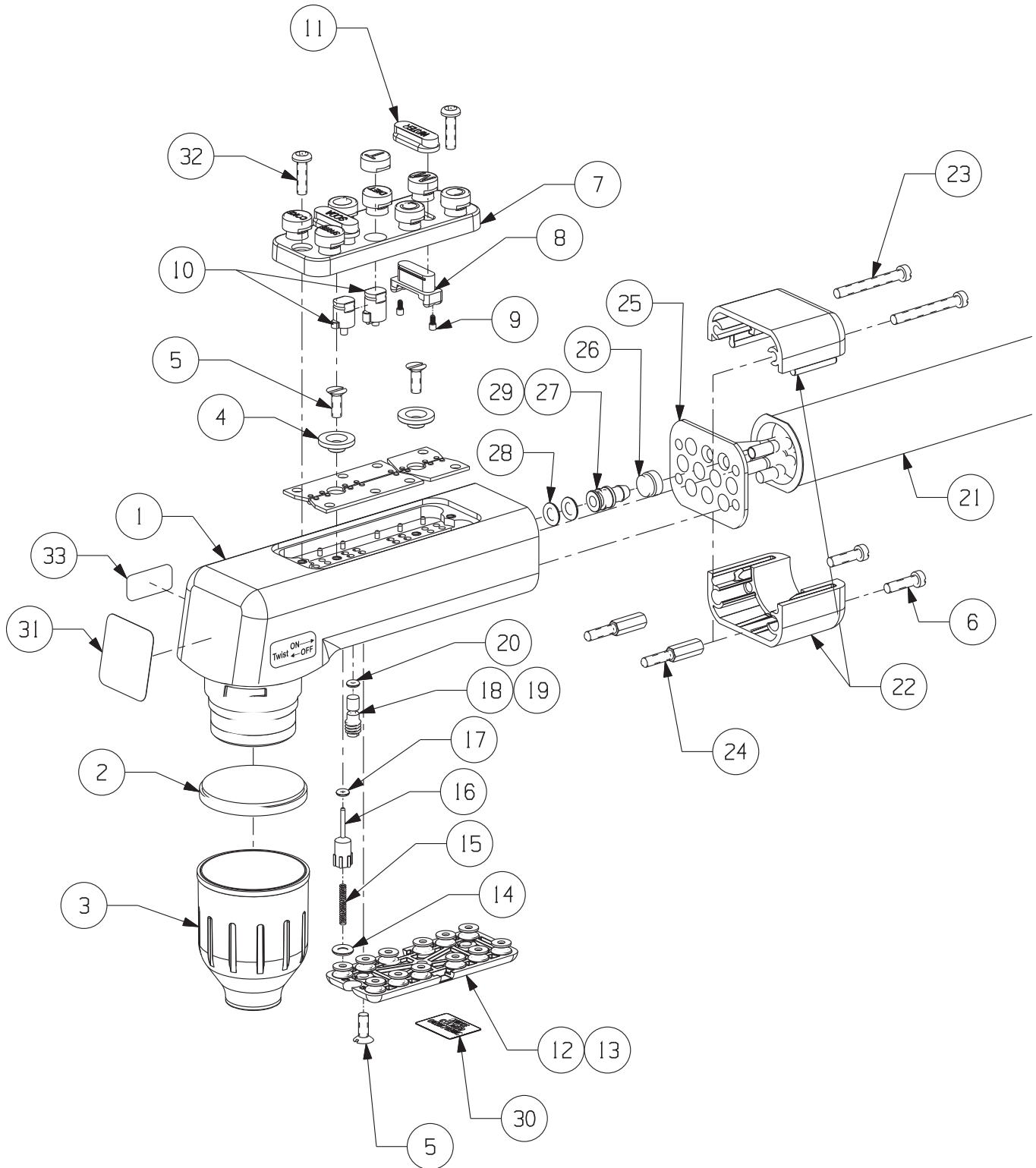

HANDLE ASSEMBLY

BARGUN HANDLE PARTS LIST		
ITEM	SCHROEDER PN	DESCRIPTION
1	645-0076	SUB-ASSY, BARGUN HANDLE,3/5B, BLACK
	645-0017	SUB-ASSY, BARGUN HANDLE,10B, BLACK
	645-0033	SUB-ASSY, BARGUN HANDLE,12B, BLACK
	645-0036	SUB-ASSY, BARGUN HANDLE,14B, BLACK
2	210-0006	SEAL, HANDLE
3	265-0194	BODY, NOZZLE, BLACK
4	265-0001	RETAINER, BUTTERFLY
5	220-0001	SCREW, 6-32X.375,100 DEG FHP
6	220-0010	SCREW, 6-32X.500, SL, FHD, SS
7	265-0229	PLATE, BUTTON, 3B, BLACK
	265-0223	PLATE, BUTTON, 5B, BLACK
	265-0205	PLATE, BUTTON, 6B JUICE, BLACK
	265-0196	PLATE, BUTTON, 8B, BLACK
	265-0202	PLATE, BUTTON, 8B JUICE, BLACK
	265-0009	PLATE, BUTTON, 10B, BLACK
	265-0089	PLATE, BUTTON, 12B, BLACK
	265-0092	PLATE, BUTTON, 14B, BLACK
8	265-0004	ACTUATOR, WATER/SODA
9	279-0014	EXTENSION, ACTUATOR, WATER/SODA
10	265-0007	ACTUATOR, SINGLE
	265-0083	ACTUATOR, SINGLE, PREMIX
11	265-0039	BUTTON, WATER
	265-0040	BUTTON, SODA
12	631-0046	PLATE SUBASSY, PLUNGER, RETAINER, 6B, BLACK
	631-0011	PLATE SUBASSY, PLUNGER, RETAINER, 10B, BLACK
	631-0040	PLATE SUBASSY, PLUNGER, RETAINER, 12B, BLACK
	631-0043	PLATE SUBASSY, PLUNGER, RETAINER, 14B, BLACK
13	645-0065	PLATE ASSY, PLUNGER, RETAINER, 6B, BLACK (W/ O-RINGS)
	645-0011	PLATE ASSY, PLUNGER, RETAINER, 10B, BLACK (W/ O-RINGS)
	645-0068	PLATE ASSY, PLUNGER, RETAINER, 12B, BLACK (W/ O-RINGS)
	645-0071	PLATE ASSY, PLUNGER, RETAINER, 14B, BLACK (W/ O-RINGS)
14	208-0007-429	O-RING, 2-007
15	215-0001	SPRING, STEM
16	265-0200	STEM/PLUNGER ASSY, 1 PC
17	208-0003-429	O-RING, 2-003
18	279-0013	SCREW, WATER, BRIX
19	625-0001	SCREW ASSY, WATER, BRIX
20	208-0003	O-RING, 2-003
21	645-0010	SHEATH, 3/5/6, 30"
	645-0060	SHEATH, 3/5/6, 48"
	645-0001	SHEATH, 8/10, 30"
	645-0061	SHEATH, 8/10, 48"
	645-0057	SHEATH, 8/10, 56"
	645-0058	SHEATH, 8/10, 72"
	645-0016	SHEATH, 12/14, 30"
	645-0053	SHEATH, 12/14, 48"
	645-0054	SHEATH, 12/14, 56"
22	631-0028	HEEL ASSY, HANDLE,6B, BLACK
	631-0010	HEEL ASSY, HANDLE,10B, BLACK
	631-0023	HEEL ASSY, HANDLE,12/14B, BLACK
23	220-0009	SCREW, 6-32X1.125, SL, FHD, SS (3/5/10B)
	220-0015	SCREW, 6-32X1.562, SL, FHD, SS (12/14B)
24	279-0011	POST, RETAINER
25	256-0012	PLATE, 3/5/6/10B
	256-0013	PLATE, 12/14B
26	265-0010	FERRULE, TUBE
27	265-0003	FITTING, INLET, HANDLE
28	208-0008-429	O-RING, 2-008
29	626-0001	FITTING ASSY, INLET, HANDLE (W/ O-RINGS)
30	808-0018	LABEL, PLATE, BOTTOM
31	808-0074	LABEL, DOMED, BG, GENERAL BEVERAGE
32	220-0012	SCREW,6-32X.500,PH,PHD,SS
33	808-0278	LABEL, TWIST-ON/OFF, BARGUN

MANIFOLD ASSEMBLY

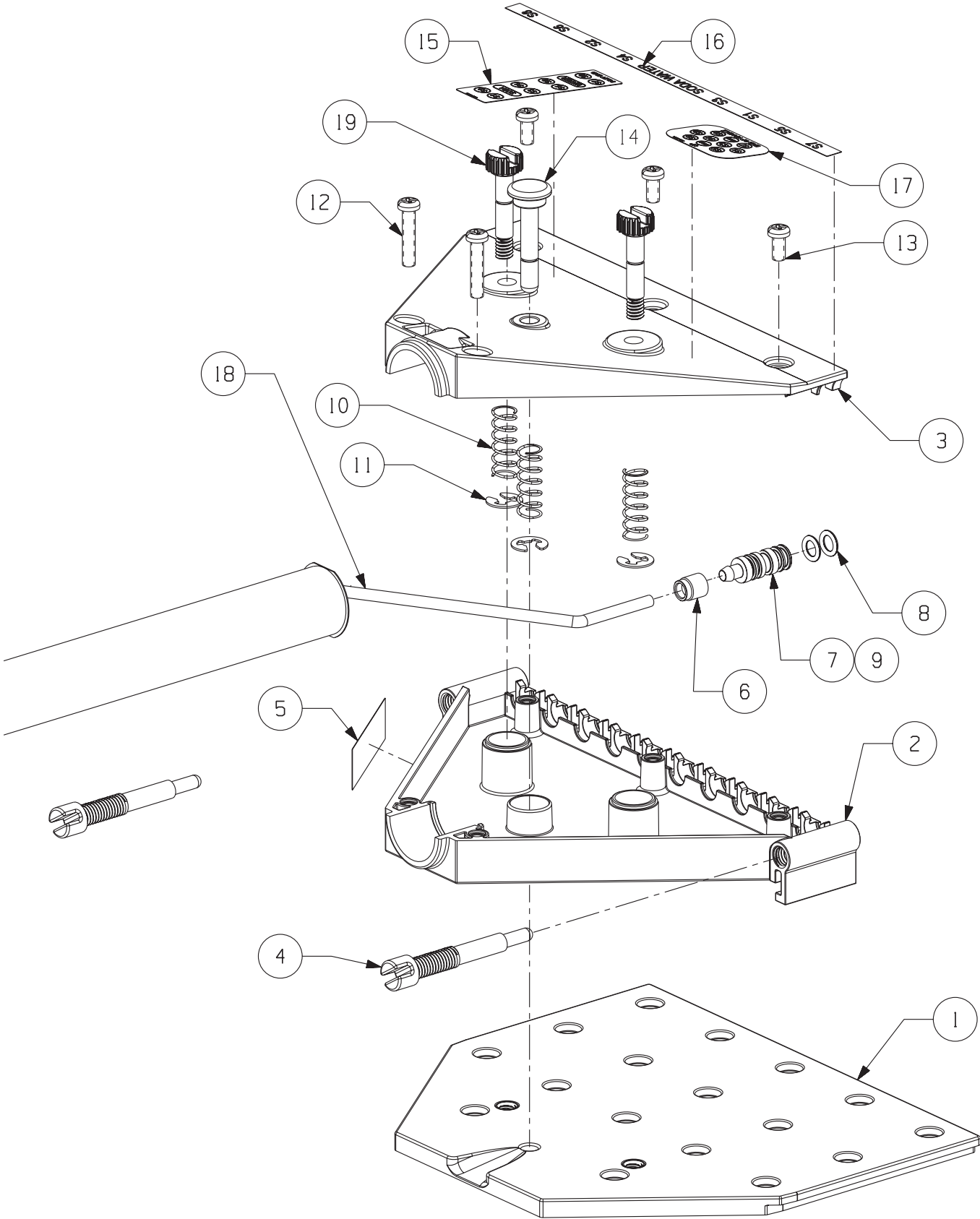

MANIFOLD ASSEMBLY

BARGUN MANIFOLD PARTS LIST		
ITEM	SCHROEDER PN	DESCRIPTION
1	265-0170	BASE, MOUNTING, 6B, BLACK
	265-0147	BASE, MOUNTING, 10B, BLACK
	265-0162	BASE, MOUNTING, 12/14B, BLACK
2	265-0168	HOUSING, TUBING, 6B, BLACK
	265-0145	HOUSING, TUBING, 10B, BLACK
	265-0160	HOUSING, TUBING, 12/14B, BLACK
3	265-0169	COVER, HOUSING, TUBING,6B, BLACK
	265-0146	COVER, HOUSING, TUBING,10B, BLACK
	265-0161	COVER, HOUSING, TUBING,12/14B, BLACK
4	265-0076	SCREW, SEPARATOR
5	808-0053	LABEL, SERIAL NUMBER, BARGUN
6	265-0264	FERRULE, FITTING, MANIFOLD
7	265-0061	FITTING, INLET, GUN
8	208-0010-429	O-RING, 2-010
9	626-0002	FITTING ASSY, INLET, GUN (W/ O-RINGS)
10	215-0005	SPRING, PIN, LATCH
11	248-0003	E-RING, .250
12	224-0003	SCREW, 8-16x.875, PLASTITE, PHSL, PHD
13	224-0002	SCREW, 8-16x.375, PLASTITE, PHSL, PHD
14	265-0075	PIN, LATCH
15	808-0076	LABEL, BUTTON LAYOUT ,5B
	808-0059	LABEL, BUTTON LAYOUT ,6B
	808-0055	LABEL, BUTTON LAYOUT ,10B
	808-0063	LABEL, BUTTON LAYOUT ,12B
	808-0064	LABEL, BUTTON LAYOUT ,14B
16	808-0060	LABEL, HOUSING LAYOUT, 5/6B
	808-0056	LABEL, HOUSING LAYOUT, 10B
	808-0062	LABEL, HOUSING LAYOUT, 12B
	808-0072	LABEL, HOUSING LAYOUT, 14B
17	808-0075	LABEL, HANDLE LAYOUT, 5B
	808-0058	LABEL, HANDLE LAYOUT, 6B
	808-0054	LABEL, HANDLE LAYOUT, 10B
	808-0061	LABEL, HANDLE LAYOUT, 12B
	808-0071	LABEL, HANDLE LAYOUT, 14B
18	030-0003	TUBE,.165X.023 WALL, SODA - SPECIFY LENGTH
	030-0004	TUBE,.165X.023 WALL, WATER - SPECIFY LENGTH
	030-0005	TUBE,.165X.023 WALL, S1 - SPECIFY LENGTH
	030-0006	TUBE,.165X.023 WALL, S2 - SPECIFY LENGTH
	030-0007	TUBE,.165X.023 WALL, S3 - SPECIFY LENGTH
	030-0008	TUBE,.165X.023 WALL, S4 - SPECIFY LENGTH
	030-0009	TUBE,.165X.023 WALL, S5 - SPECIFY LENGTH
	030-0010	TUBE,.165X.023 WALL, S6 - SPECIFY LENGTH
	030-0011	TUBE,.165X.023 WALL, S7 - SPECIFY LENGTH
	030-0012	TUBE,.165X.023 WALL, S8 - SPECIFY LENGTH
	030-0013	TUBE,.165X.023 WALL, S9 - SPECIFY LENGTH
	030-0014	TUBE,.165X.023 WALL, S10 - SPECIFY LENGTH
	030-0015	TUBE,.165X.023 WALL, S11 - SPECIFY LENGTH
030-0016	TUBE,.165X.023 WALL, S12 - SPECIFY LENGTH	
19	265-0250	SCREW, 1/4-20, RETAINER, BARGUN

FLOW CONTROL MODULE ASSEMBLY

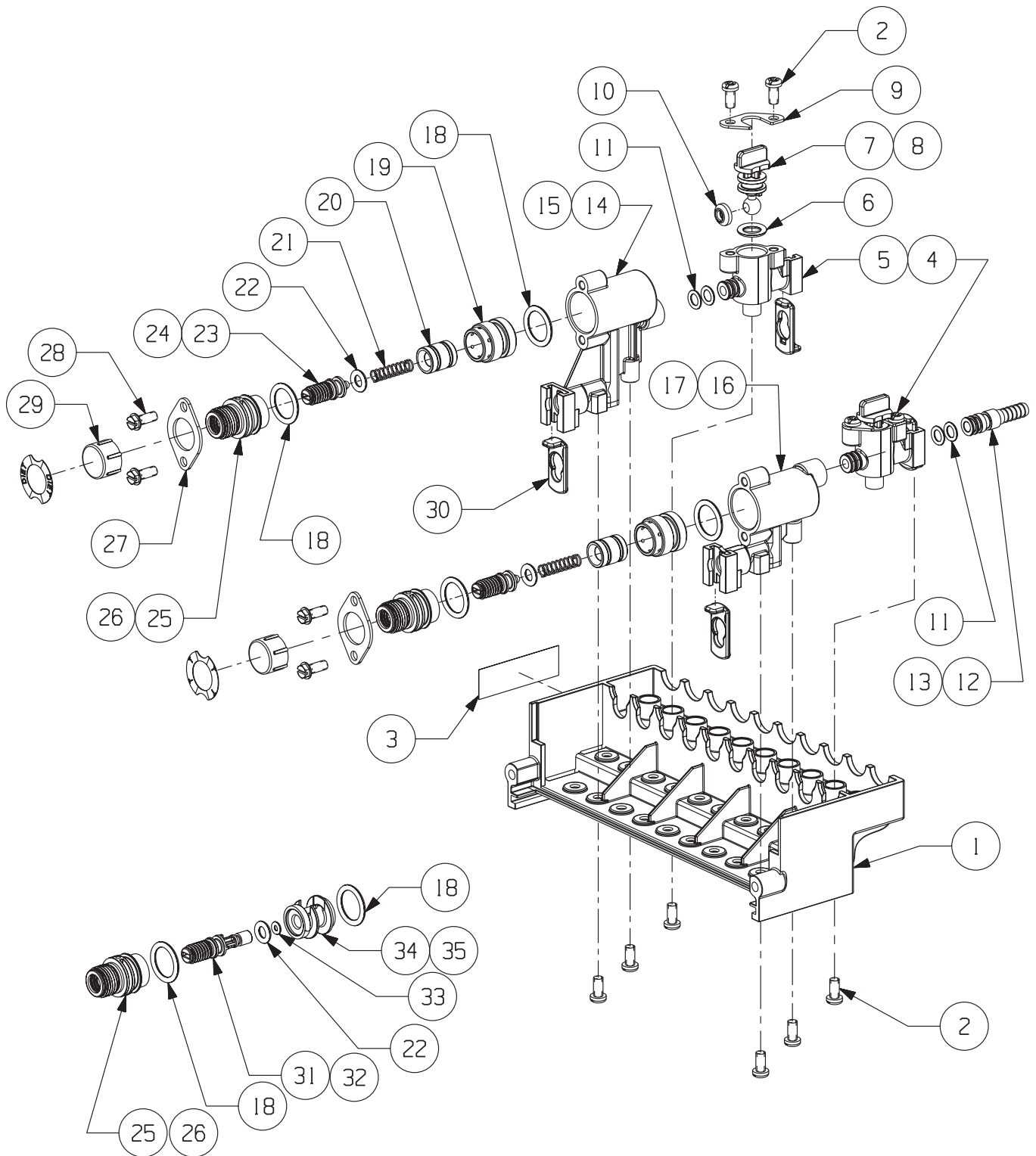

FLOW CONTROL MODULE ASSEMBLY

BARGUN FLOW CONTROL MODULE PARTS LIST		
ITEM	SCHROEDER PN	DESCRIPTION
1	265-0167	HOUSING, VALVES, 6B, BLACK
	265-0144	HOUSING, VALVES, 10B, BLACK
	265-0159	HOUSING, VALVES, 12/14B, BLACK
2	224-0002	SCREW, 8-16x.375, PLASTITE, PHSL, PHD
3	808-0053	LABEL, SERIAL NUMBER, BARGUN
4	637-0003	ASSY, VALVE, BACKBLOCK, BLACK
5	265-0139	BODY, BACKBLOCK, BLACK
6	208-0110	O-RING, 2-110
7	265-0044	STEM, BODY
8	625-0009	STEM ASSY, SHUT-OFF (W/O-RING)
9	256-0011	RETAINER, STEM
10	265-0043	WASHER, STEM
11	208-0010	O-RING, 2-010
12	279-0016	FITTING,.375 O-RING X.250 BARB
	279-0017	FITTING,.375 O-RING X.375 BARB
13	625-0004	FITTING ASSY, .375 O-RING X.250 BARB (W/O-RING)
	625-0005	FITTING ASSY, .375 O-RING X.375 BARB (W/O-RING)
14	265-0048	BODY, FLOW CONTROL, 1, NATURAL
	265-0140	BODY, FLOW CONTROL, 1, BLACK
15	639-0001	ASSY, VALVE, FLOW CTRL, SODA 1, BLK BONNET
	639-0005	SUB-ASSY,FLOW CONTROL,SYRUP 1, BLACK
16	265-0049	BODY, FLOW CONTROL, 2, NATURAL
	265-0142	BODY, FLOW CONTROL, 2, BLACK
17	639-0002	ASSY, VALVE, FLOW CTRL, SODA 2, BLK BONNET
	639-0006	SUB-ASSY,FLOW CONTROL,SYRUP 2, BLACK
18	208-0114	O-RING, 2-114
19	277-0001	SLEEVE, WATER/SYRUP
20	277-0002	PISTON, SYRUP
	277-0003	PISTON, WATER
	215-0002	SPRING, SYRUP
21	215-0002	SPRING, SYRUP
	215-0003	SPRING, SODA
22	208-0108	O-RING, 2-108
23	265-0041	PLUG, ADJUST,FC, RED
24	625-0002	PLUG ADJUSTER SUB-ASSY, RED (W/ O-RING)
25	265-0042	BONNET, BLACK
26	625-0007	BONNET SUBASSY, BLACK (W/ O-RING)
27	256-0010	RETAINER, BONNET
28	224-0001	SCREW, 8-16x.500, PLASTITE, SL, HHD
29	265-0052	CAP, BONNET
30	265-0063	RETAINER, CLIP, FITTING
31	265-0070	PLUG ADJUST,MC, GREEN
32	625-0003	PLUG ADJUSTER SUB-ASSY, GREEN (W/ O-RING)
33	208-0006	O-RING, 2-006
34	265-0099	CONTROL, ORIFICE
35	625-0008	CONTROL ORIFICE SUBASSY (W/O-RING)

MECHANICAL MODULE ASSEMBLY

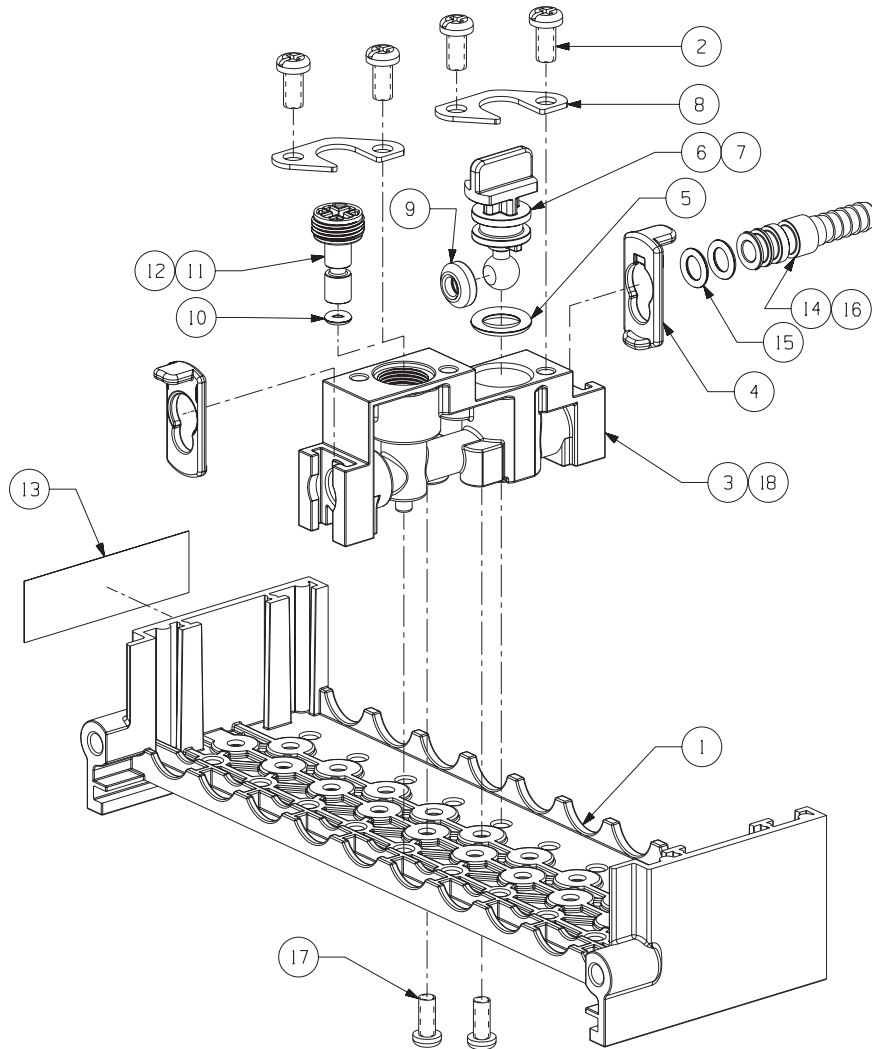

BARGUN MECHANICAL CONTROLS MODULE PARTS LIST

ITEM	SCHROEDER PN	DESCRIPTION
1	265-0193	HOUSING,MOUNTING,VALVE,BOTTLER,6B, BLACK
	265-0180	HOUSING,MOUNTING,VALVE,BOTTLER,10B, BLACK
	265-0192	HOUSING,MOUNTING,VALVE,BOTTLER,12/14B, BLACK
2	224-0002	SCREW, 8-16x.375, PLASTITE, PHSL, PHD
3	265-0211	BODY,VALVE,BOTTLER, BLACK
4	265-0063	RETAINER, CLIP, FITTING
5	208-0110	O-RING, 2-110
6	265-0044	STEM, BODY
7	625-0009	STEM ASSY, SHUT-OFF (W/ O-RING)
8	256-0011	RETAINER, STEM
9	265-0043	WASHER, STEM
10	208-0006	O-RING, 2-006
11	265-0154	STEM,BODY,VALVE,METER
12	625-0010	STEM ASSY, METER (W/ O-RING)
13	808-0053	LABEL, SERIAL NUMBER, BARGUN
14	279-0016	FITTING,.375 O-RING X.250 BARB
	279-0017	FITTING,.375 O-RING X.375 BARB
15	208-0010	O-RING, 2-010
16	625-0004	FITTING ASSY, .375 O-RING X.250 BARB (W/ O-RINGS)
	625-0005	FITTING ASSY, .375 O-RING X.375 BARB (W/ O-RINGS)
17	224-0005	SCREW, 6-19x.375, PLASTITE, PH, PHD
18	639-0016	ASSY, VALVE, BOTTLER, BARGUN, BLACK

MOUNTING PLATE SCREW PLACEMENT

6 BUTTON/ENERGY MOUNTING PLATE 5 MOUNTING SCREWS

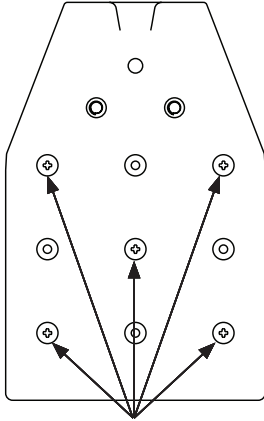

USE THESE MOUNTING HOLES FOR BEST STABILITY

10 BUTTON MOUNTING PLATE 8 MOUNTING SCREWS

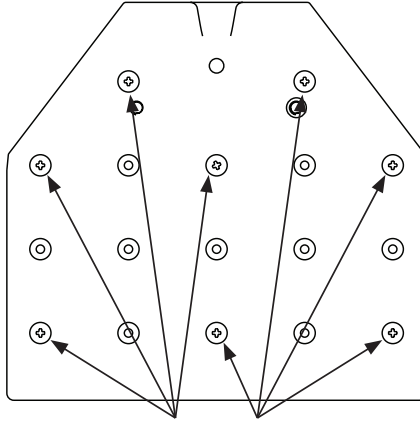

USE THESE MOUNTING HOLES FOR BEST STABILITY

12/14 BUTTON MOUNTING PLATE 10 MOUNTING SCREWS

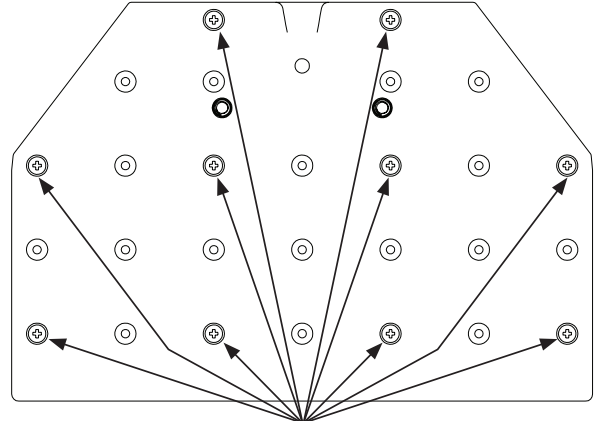

USE THESE MOUNTING HOLES FOR BEST STABILITY

PATENT NUMBERS

UNITED STATES

7,658,006
8,109,413
8,123,079
8,336,736
8,387,829
8,418,888
8,479,954
8,770,442
8,807,395
8,814,003
D697,753
D717,590
D717,591
D717,592
D717,593

UNITED KINGDOM

002159194
GB2468792
GB2474741
GB2476347
GB2480531
GB2480532
GB2480533
GB2482813
GB2490054
GB2490055
GB2490814
GB2490815

MEXICO

MX/a/2010/001029
41390
317084

AUSTRALIA

346264
346389

EUROPEAN PATENT

2300353
2336076